

Computer Server Hosting Centre

DATA CENTRE

File servers, application servers and simple databases are grouped in data centres which need to ensure high system availability, as companies, banks and even hospitals use them to store and manage their data.

A computer hosting centre needs to be extremely reliable, particularly in order to ensure uninterrupted service for its customers. To prevent power outages, which would shut down the system and suspend delivery of the required service, their power supply system is usually backed by a standby power supply.

Installation

Maintenance

Recording

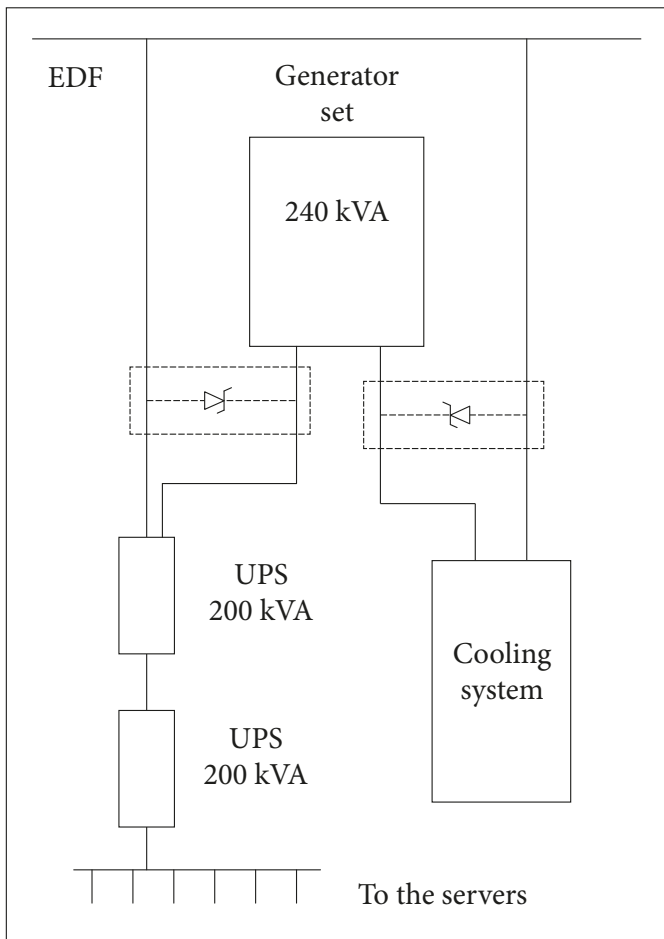

In the case considered here, the computer room is equipped with 2 uninterruptible power supplies (UPS) and an air-conditioning system operating constantly to cool the ambient air.

The two 200 kVA uninterruptible power supplies operate in "1+1" redundant mode. Thus, if one of the UPSs fails, the second can handle the whole load on its own. To optimize the installation's reliability, the customer decides to add a 240 kVA generator set. Once installation is complete, the customer needs to check that the whole standby emergency system reacts satisfactorily if the main power network fails.

Measurements taken with a Qualistar+ during generator-set load-takeover tests will then confirm the installation's reliability.



Did you know?

Usually, a generator set mainly comprises a petrol or diesel engine, an alternator and a speed-control system.

Important: an electrical generator set can instantaneously supply only one third of its rated power, so a 240 kVA generator set will only supply 80 kVA when it starts up and will only achieve its rated power when it has reached its full operating speed.

1/ First series of measurements: no-load test of the generator set

The first measurements concern operation of the generator set without a load.

On the generator-set output, it is important to check any interference or losses which the generator set may cause on the power supply, thus reducing its quality.

By connecting the Qualistar+ below the generator-set output, we can therefore capture the voltage and current waveforms, in particular during start-up (inrush). The voltage levels are well balanced and as expected, with low distortion (approximately 2%), and remain between 230 V and 233 V once the signal has stabilized. (fig.1)

Fig.1

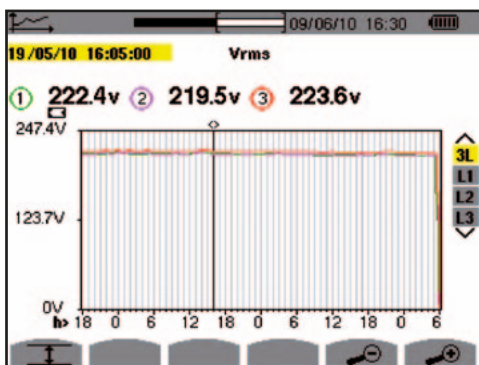

RMS values of the phase-neutral voltages on the 3 phases (min, average, max)

In the illustration showing the frequencies, the time necessary for the generator set to stabilize is clearly visible.

However, the frequency of the generator-set output voltages is subject to variations (average frequency 49.60 Hz). These variations may prevent proper operation of the UPSs and eventually damage them. (fig.2)

Fig.2

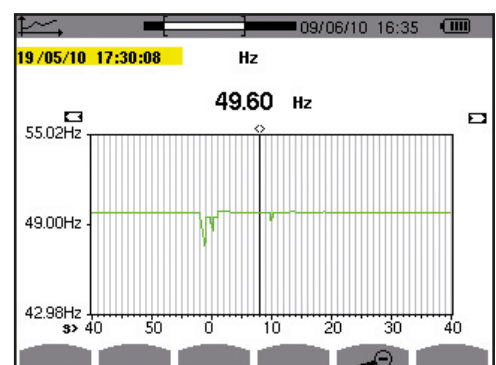

Frequencies (min, avg, max)

The apparent power consumed on the output of the generator set is 130 kVA (measurement taken during recharging of the UPS batteries), so the generator set operates at 60% capacity in this context. (fig.3) Further measurements are now taken at the same point as before, revealing a significant deterioration of the voltage, with a THD of around 20%!

Fig.3

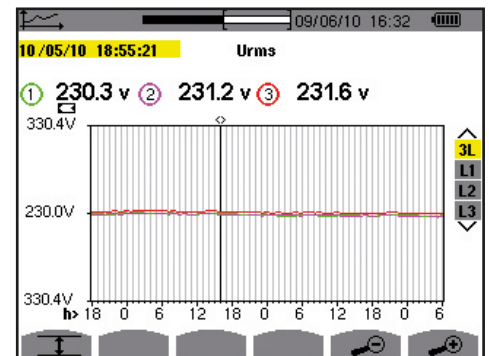

Fig.4

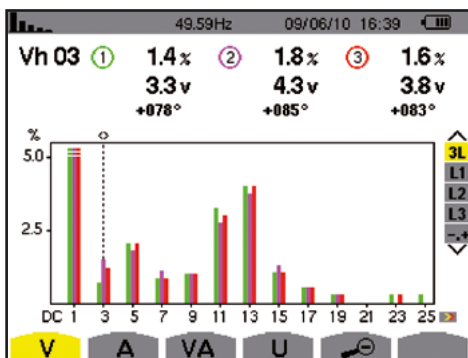
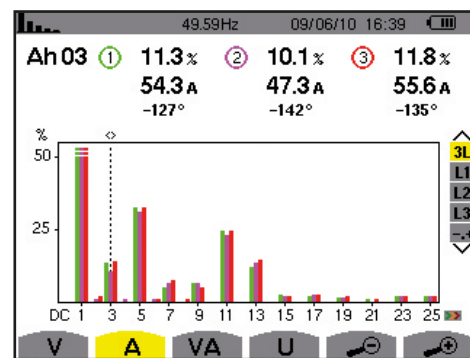

Fig.5



Analysis of the current waveforms shows a THD of around 35% on the current, even though the levels are balanced on the 3 phases.

It is clear that the 11th and 13th-order harmonics have a lower amplitude than the 5th-order harmonics.

At the same time, we take measurements on the outputs of the UPSs where there are frequency variations of approximately 0.5 Hz/s.

Comparison of the measurements shows:

- a significant deterioration of the voltage
- the influence of the generator-set's source impedance, which is inductive

It is clear that the generator set's source impedance has a direct effect on the harmonics of currents drawn by the load.

The standby system in its present form does not ensure reliable operation if the main power network fails. The solution planned involves requalifying the generator set so that the effects of the current harmonics on the load are attenuated. There are several ways of doing this:

- passive filters: these help to reduce the harmonic impedance of the network by means of filters (usually capacitors or inductors)
- active filters: these inject harmonics with the same amplitude as those present, but in phase-opposition, thus cancelling them out.

The customer has chosen the solution involving active harmonic compensation. 3 active filters are installed to compensate 30 distorting Amperes each, giving 90 distorting Amperes in total.

With active harmonic compensation

In this second series of tests, the total apparent power consumed at the generator-set output reaches a maximum of 239 kVA. This power level corresponds to the maximum load that the generator set is capable of supplying (240 kVA).

By taking the same measurements as before, we can draw up the following comparative table:

	Without active compensation	With active compensation
Current drawn on the phases	187A, 183A, 184A	319A, 311A, 320A
Generator-set apparent power	130 kVA	239 kVA
RMS phase-neutral voltages	230 V and 233 V	227 V et 234 V
THD U	20%	Between 10 and 12%
Value H5	32 V	15 V
THD I	35%	10%

Conclusion

The active harmonic compensation set-up is satisfactory and can be used to requalify the voltages supplied by the generator set in a maximum-load situation. (fig.3)

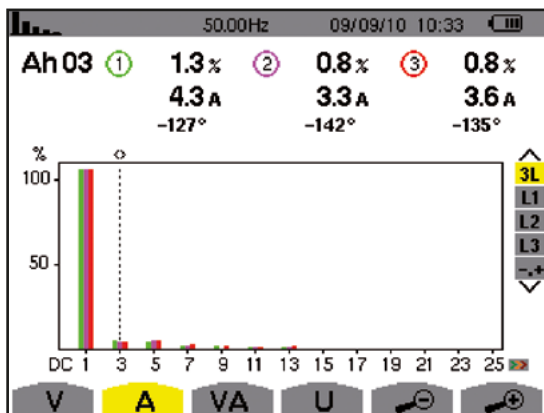

Fig6

This type of installation can be found in server farms, production industries and even hospitals. The quality of the UPSs is also an important factor. Indeed, to avoid oversizing the generator set, the UPSs must also have a low THD rating.

Did you know?

According to the NF C 15 100 standard, there are several pollution levels corresponding to the THD level on the network:

THDU < 5% and THDI < 10 %

5 % < THDU < 8 % or 10 % < THDI < 50 %

THDU > 8 % and THDI > 50 %

No significant consequences

Pollution with possibility of problems depending on the equipment

High pollution, probable malfunctions

FRANCE
Chauvin Arnoux
 190, rue Championnet
 75876 PARIS Cedex 18
 Tél : +33 1 44 85 44 85
 Fax : +33 1 46 27 73 89
 info@chauvin-arnoux.fr
 www.chauvin-arnoux.fr

UNITED KINGDOM
Chauvin Arnoux Ltd
 Unit 1 Nelson Ct, Flagship Sq, Shaw Cross Business Pk
 Dewsbury, West Yorkshire - WF12 7TH
 Tél : +44 1924 460 494
 Fax : +44 1924 455 328
 info@chauvin-arnoux.co.uk
 www.chauvin-arnoux.com

MIDDLE EAST
Chauvin Arnoux Middle East
 P.O. BOX 60-154
 1241 2020 JAL EL DIB (Beyrouth) - LIBAN
 Tél : +961 1 890 425
 Fax : +961 1 890 424
 camie@chauvin-arnoux.com
 www.chauvin-arnoux.com

