

# FLEXIBLE PROBES FOR AC CURRENT

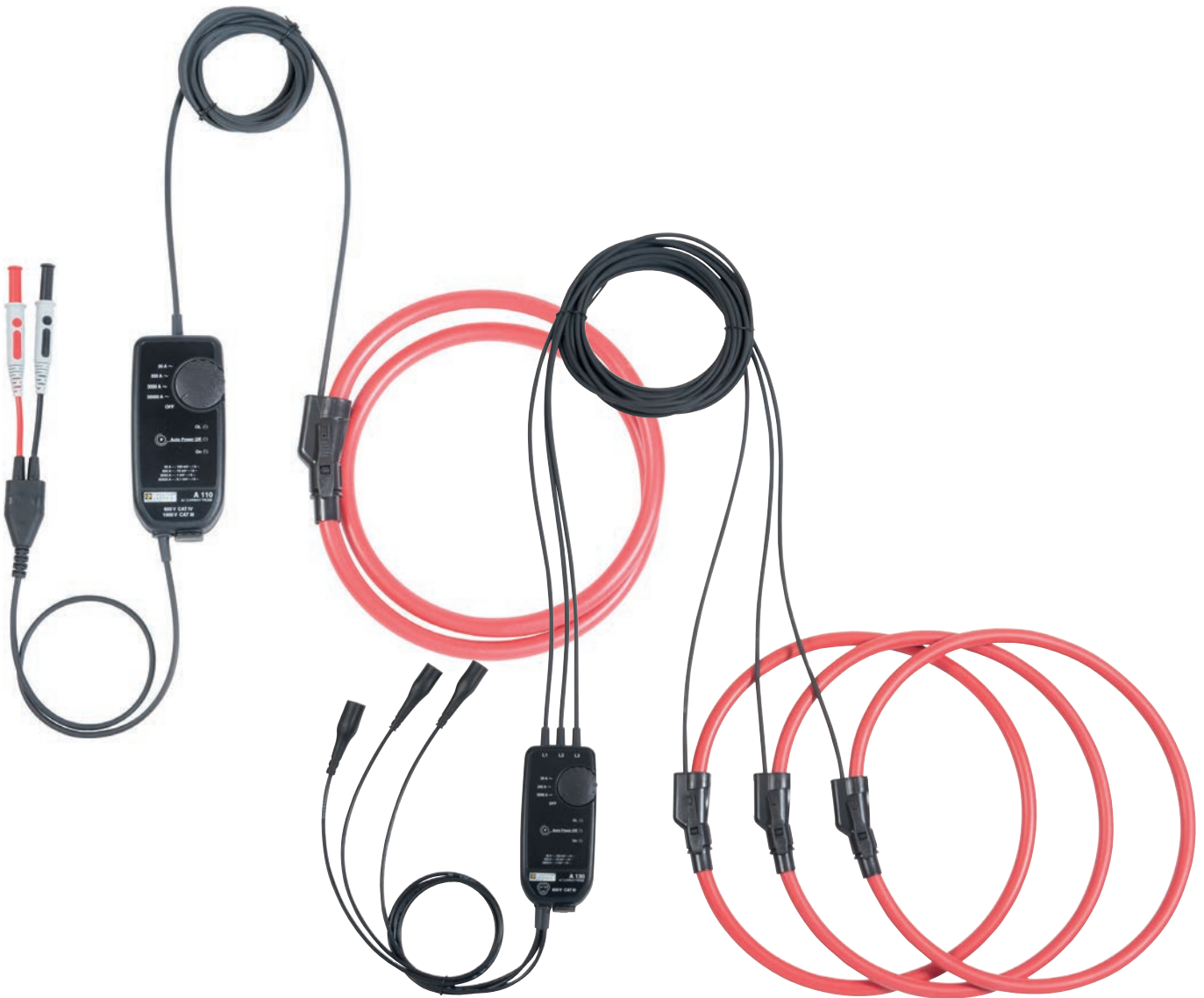

## Model AmpFlex®

These flexible current probes are as at home measuring low AC currents of a few tens mA as they are measuring high currents of several tens of kA.

Their main point of interest is their flexibility and the ease with which electrical conductors of all shapes and sizes (cables, busbars) and degrees of accessibility can be gripped.

They have a number of other advantages; they are lightweight (no magnetic circuit), they do not suffer from the saturation effect and their high level of accuracy combined with minimal phase shift make them perfect for power measurement applications.

- **AmpFlex® A110 series:**

The sensors in the A110 series have a flexible core connected by a shielded cable to a small unit containing processing electronics. This IP54 unit offers 4 measurement calibres and can be connected directly to any multimeter, wattmeter or logger. The length of the sensors in this series (up to 120 cm as standard) enables you to clamp cables with a large cross-section or several conductors simultaneously. The A110 can be used for measurements up to 30 kA AC.

The AmpFlex® A110 offers IP67 ingress protection and can be connected to the AC voltage input (mV AC, V AC) of any multimeter or measuring instrument equipped with Ø 4 mm female banana plugs.

- **AmpFlex® A130:**

The A130 model is a version of the A110 series adapted for measurements on three-phase installations. It is equipped with BNC connections. The processing unit offers 3 measurement calibres. The A130 sensor can be connected to the AC voltage inputs (mV AC, V AC) of any power analyser, logger or measuring instrument equipped with BNC plugs.

# FLEXIBLE PROBES FOR AC CURRENT

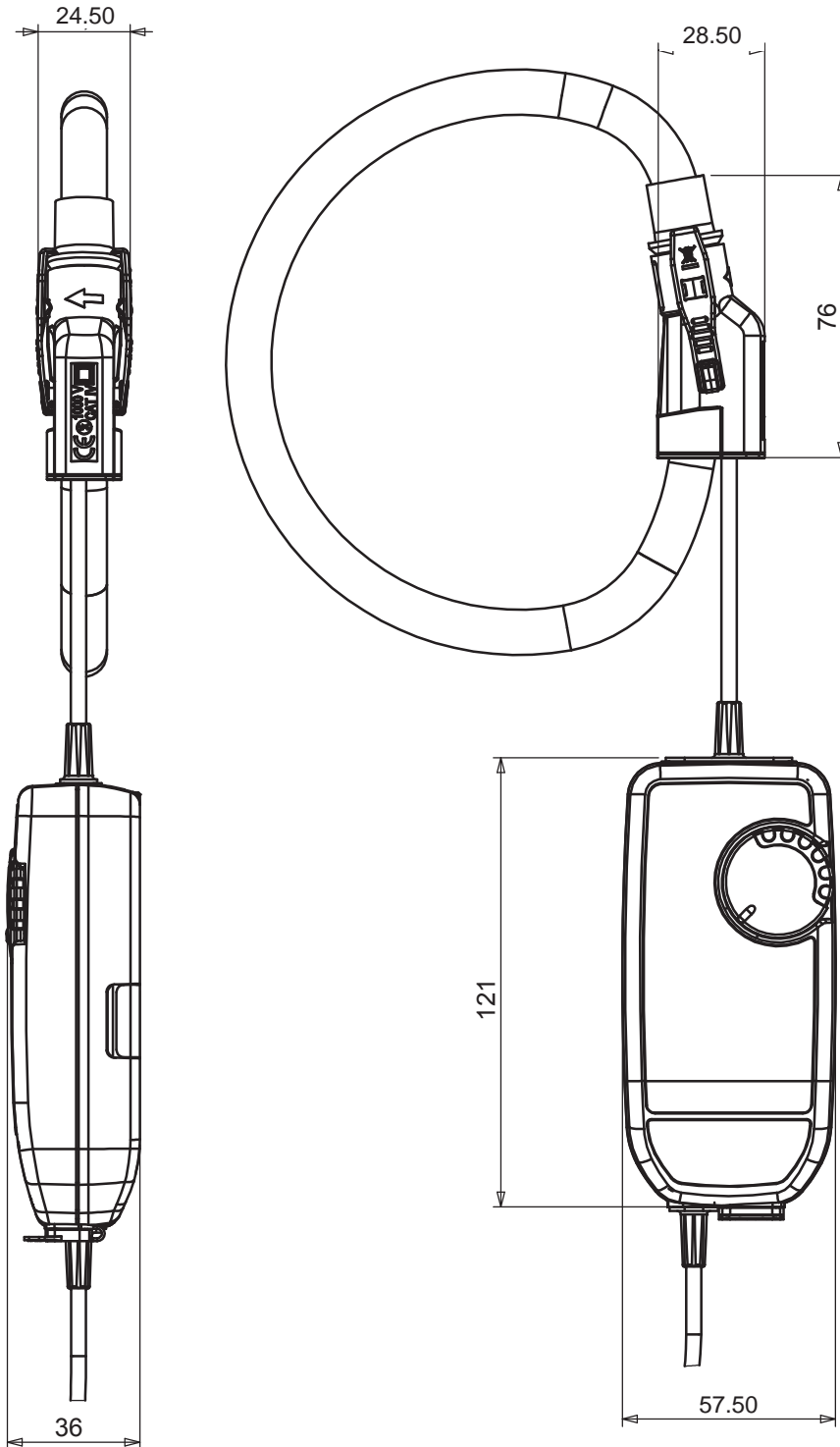

# FLEXIBLE PROBES FOR AC CURRENT

## Model A110 3-30-300-3,000/3

Current	3 A AC	30 A AC	300 A AC	3,000 A AC
Output	1 mV/mA	100 mV/A	10 mV/A	1 mV/A

### Description

The AmpFlex® A110 is a flexible sensor which comprises an active part (Rogowski coil) and a casing containing an electronic processing unit.

Unlike current clamps using magnetic circuits, the AmpFlex® models are flexible sensors without magnetic saturation constraints. As a result, they offer excellent linearity, low phase shift, a large dynamic range for measurement (up to several kA) while remaining easy to use.

The sensors' flexibility makes it simple to clamp and measure any conductor, whatever its type (cable, busbar, strand, etc. and accessibility).

The design of the click-together opening and closing system means it can be handled with protective gloves.

The AmpFlex® A110 can be connected to the AC voltage input (mV AC, V AC) of any multimeter or measuring instrument equipped with Ø 4 mm female banana plugs.

The AmpFlex® A110 can be powered by batteries or a standard external power supply. If the power supply fails, the instrument's batteries take over.

To maximize the battery life, the MiniFlex A110 has an automatic standby system which can be deactivated at start-up to perform long-term measurement campaigns.

The MiniFlex A110 has 3 green, yellow and red LEDs indicating, respectively, the power supply status, the status of the automatic standby function and any overruns of the measurement capacity.



### Specifications for current measurement <sup>(1)</sup>

Calibre ( $I_N$ )	3 A	30 A	300 A	3,000 A
Measurement range in use	0.08 .. 3 A AC	0.5 .. 30 AC	0.5 .. 300 AC	0.5 .. 3,000 AC
Specified measurement range	0.5 .. 3 AC	2 .. 30 AC	5 .. 300 AC	50 .. 3,000 AC
Output/input ratio	1 V / A (1 mV / mA)	100 mV / A	10 mV / A	1 mV / A
Bandwidth at -3 dB	10 Hz .. 10 kHz	10 Hz .. 20 kHz	10 Hz .. 20 kHz	10 Hz .. 20 kHz
Frequency limitation	Null	Null	Null	See curve
Intrinsic uncertainty	$\leq 1\% + 40 \text{ mV}$	$\leq 1\% + 4 \text{ mV}$	$\leq 1.5\% + 0.4 \text{ mV}$ ( $I < 10\% I_N$ ) $\leq 1\% + 0.4 \text{ mV}$ ( $I \geq 10\% I_N$ )	$\leq 1.5\% + 0.04 \text{ mV}$ ( $I < 10\% I_N$ ) $\leq 1\% + 0.04 \text{ mV}$ ( $I \geq 10\% I_N$ )
Phase shift at 50 Hz	$\leq 1^\circ$ (0.5° typical)	$\leq 1^\circ$ (0.5° typical)	$\leq 1^\circ$ (0.5° typical)	$\leq 1^\circ$ (0.5° typical)

### Electrical specifications <sup>(1)</sup>

- Operating voltage:**  
1,000 V<sub>RMS</sub> (Cat. IV)
- Battery:**  
Two 1.5 V batteries (NEDA 15A, IEC LR6, AA)  
+5 V DC via a µUSB Type B connector
- Battery life <sup>(2)</sup>:**  
300 hours typical  
1,800 10-minute approx. measurements
- Consumption:**  
10 µA (OFF position)  
90 µA (sleep mode)
- Battery level indication:**  
Flashing green LED (batteries voltage > 2 V)
- Influence of battery voltage:**  
 $\leq 0.1\%$  (0.02 % typical) from 3.1 V to 2 V
- Influence of temperature:**  
 $\leq 0.5\%$  (0.15 % typical) of output signal per 10 °K
- Influence of relative humidity:**  
 $\leq 0.5\%$  (0.2 % typical) of output signal
- Influence of conductor position in the sensor <sup>(3)</sup>:**  
 $\leq 2.5\%$  (1 % typical)
- Influence of sensor deformation <sup>(4)</sup>:**  
 $\leq 1\%$  (0.2 % typical)
- Influence of adjacent conductor <sup>(5)</sup>:**  
 $\leq I_{ADJ} \times 1\%$  (2 % near click-lock system)  
(0.2 % typical)
- Input impedance of the measuring instrument:**  
 $\geq 1 \text{ M}\Omega$
- Common mode rejection <sup>(6)</sup>:**  
 $\leq 80 \text{ dB}$  (100 dB typical)
- Influence of the measurement instrument's impedance Z:**  
 $\leq 0.1\%$  at 10 kΩ

# FLEXIBLE PROBES FOR AC CURRENT

## Model A110 3-30-300-3,000/3

### Mechanical specifications

- **Clamping capacity:**  
Model length 45 cm: Ø max 12 cm  
Model length 80 cm: Ø max 23.5 cm
- **Bending radius:**  
≥ 40 mm
- **Operating temperature:**  
-10°C to +55°C
- **Storage temperature:**  
-40°C to +70°C
- **Max. temperature of clamped conductor (measured):**  
90 °C for 10 minutes max.
- **Relative humidity for operation:**  
0 to 85 % RH with a linear decrease above 35 °C
- **Operating altitude:**  
0 to 2,000 m
- **Casing protection rating (leakproofing):**  
Intermediate casing: IP54  
Flexible sensor: IP 67  
According to IEC 60529 Ed. 2.2-2013

- **Drop test:**  
1 m
- **Self-extinguishing capability:**  
Casing: UL94-V0  
Sensor: UL94 V0
- **Dimensions:**  
Intermediate casing: 120 x 55 x 39 (overall)  
Length of intermediate cable linking the sensor/processing unit: 2 m  
Length of output cable: 0.5 m  
Ø of sensor: 12 mm  
Connection cable Ø: 4 mm
- **Weight:**  
Model length 45 mm: 450 g  
Sensor: 30 g / 10 cm
- **Colours:**  
Sensor: red  
Sensor closing system: dark grey  
Intermediate casing: Dark grey
- **Output:**  
Two-wire cable with reinforced or double insulation terminated by 2 red and black isolated male banana plugs Ø 4 mm

### Safety specifications

- **Electrical safety:**  
Class II equipment with double or reinforced insulation between the primary and the secondary (winding connected to the connection cable) as per EN 61010-1 and 61010-2-032 Ed. 03-2012:  
- Sensor:  
Type B  
1,000 V Cat. IV pollution degree 2  
Intermediate casing:  
600 V Cat. III between the terminals and the external enclosure of the casing
- **Electromagnetic compatibility (EMC) :**  
Complies with the industrial environments according to EN 61326-1 Ed. 02-2012:  
- Immunity to radiated fields: at 3 V/m, error ≤ 5% of measuring range (criterion A)

- (1) Conditions of reference: 23 °C ± 5 °K, 20 % to 75 % RH  
Battery voltage 3.2 V ± 0.1 VDC  
Frequency and form of signal measured: 30 to 440 Hz sinusoidal  
Continuous magnetic field < 40 A/m  
Absence of external AC magnetic field  
Absence of external electrical field  
Measured conductor centred in the circular sensor (coil) after operation for 1 minute  
Measurement instrument input impedance ≥ 1 MΩ
- (2) With 3,000 mA/h batteries, for a supplied voltage between 3.2 V and 1.8 V (1.6 V to 0.9 V per battery), giving an average voltage of 2.8 V
- (3) Whatever the conductor's position within the loop, as long as the sensor is not distorted (circular sensor)
- (4) Oblong shape
- (5) Adjacent conductor carrying an AC current  $I_{adj}$ , in contact with the sensor
- (6) For a 600 V voltage applied between the enclosure and the secondary

### 3,000 A calibre

Frequency limitation according to amplitude

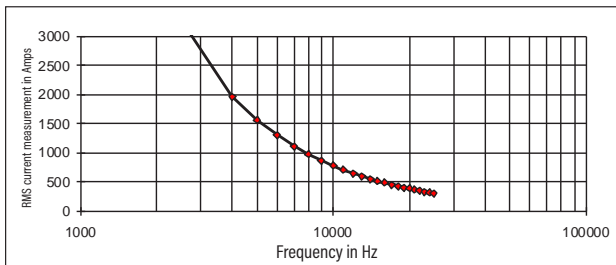

To order	Reference
AmpFlex® A110 3-30-300-3,000 A / 3 V, sensor length 45 cm, Output via cable terminated by 2 x Ø 4 mm isolated male banana plugs	P01120630
AmpFlex® A110 3-30-300-3,000 A / 3 V, sensor length 80 cm, Output via cable terminated by 2 x Ø 4 mm isolated male banana plugs	P01120631

# FLEXIBLE PROBES FOR AC CURRENT

## Model A110 3-30-300-3,000/3

### Frequency response

#### 3 A calibre

Typical error on measurement according to frequency for a current of 2 A

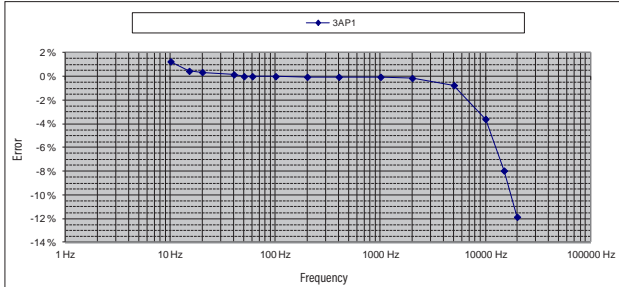

#### 30 A calibre

Typical error on measurement according to frequency for a current of 20 A

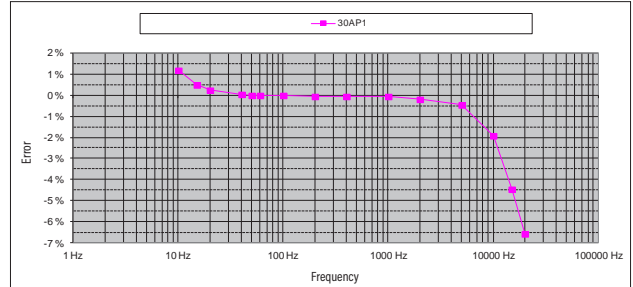

Typical phase shift according to frequency for a current of 2 A

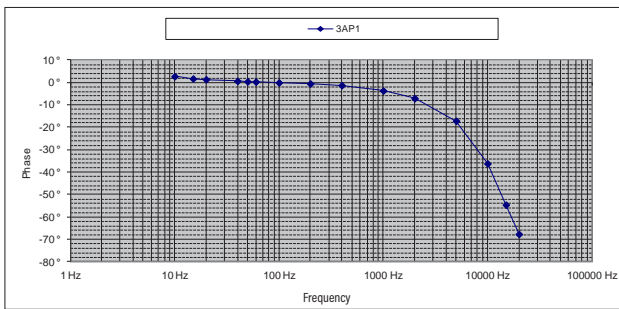

Typical phase shift according to frequency for a current of 20 A

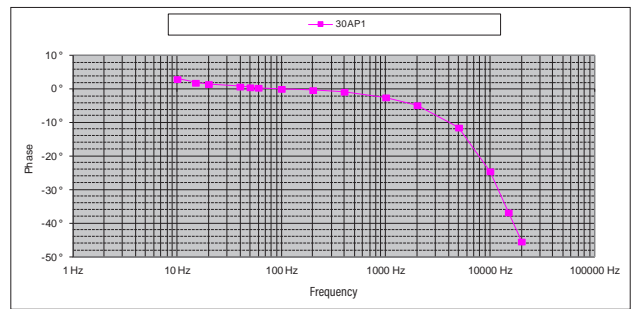

#### 300 A calibre

Typical error on measurement according to frequency for a current of 20 A

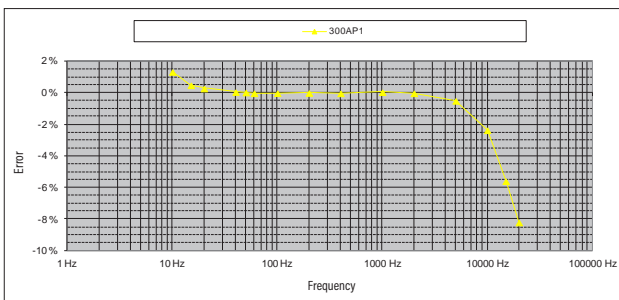

Typical phase shift according to frequency for a current of 20 A

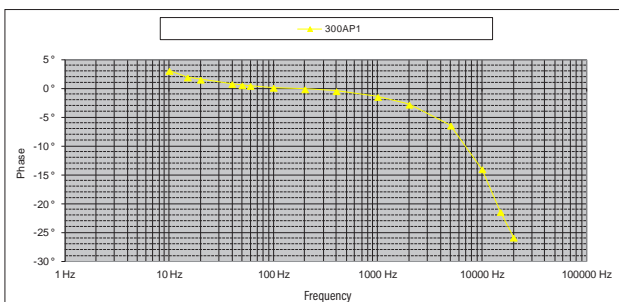

#### 3,000 A calibre

Typical error on measurement according to frequency for a current of 20 A

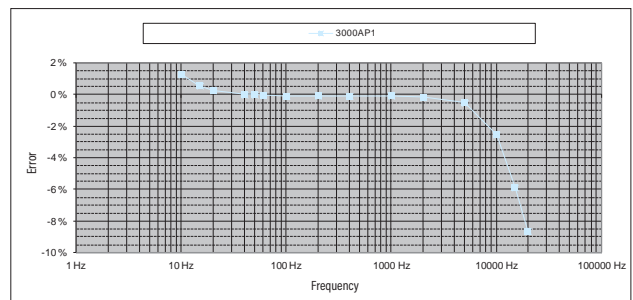

Typical phase shift according to frequency for a current of 20 A

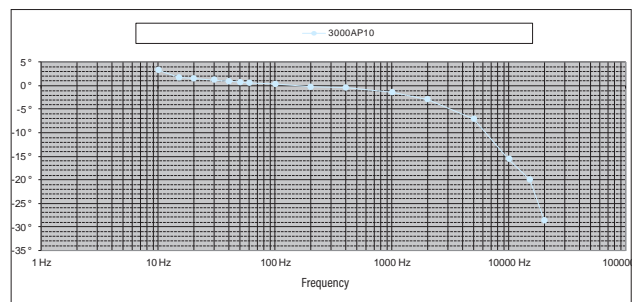

# FLEXIBLE PROBES FOR AC CURRENT

## Model A110 30-300-3,000-30,000/3

Current	30 A AC	300 A AC	3,000 A AC	30,000 A AC
Output	100 mV/A	10 mV/A	1 mV/A	0.1 mV/A

### Description

The AmpFlex® A110 is a flexible sensor which comprises an active part (Rogowski coil) and a casing containing an electronic processing unit.

Unlike current clamps using magnetic circuits, the AmpFlex® models are flexible sensors without magnetic saturation constraints. As a result, they offer excellent linearity, low phase shift, a large dynamic range for measurement (up to several kA) while remaining easy to use.

The sensors' flexibility makes it simple to clamp and measure any conductor, whatever its type (cable, busbar, strand, etc. and accessibility).

The design of the click-together opening and closing system means it can be handled with protective gloves.

The AmpFlex® A110 can be connected to the AC voltage input (mV AC, V AC) of any multimeter or measuring instrument equipped with Ø 4 mm female banana plugs.

The AmpFlex® A110 can be powered by batteries or a standard external power supply. If the power supply fails, the instrument's batteries take over.

To maximize the battery life, the MiniFlex A110 has an automatic standby system which can be deactivated at start-up to perform long-term measurement campaigns. The MiniFlex A110 has 3 green, yellow and red LEDs indicating, respectively, the power supply status, the status of the automatic standby function and any overruns of the measurement capacity.



### Specifications for current measurement <sup>(1)</sup>

Calibre (I <sub>N</sub> )	30 A	300 A	3,000 A	30,000 A
Measurement range in use	0.5 .. 30 A AC	0.5 .. 300 A AC	0.5 .. 3,000 A AC	0.5 .. 30,000 A AC
Specified measurement range	0.5 .. 30 A AC	10 .. 300 A AC	10 .. 3,000 A AC	50 .. 30,000 A AC
Output/input ratio	100 mV / A	10 mV / A	1 mV / A	0.1 mV / A
Bandwidth at -3 dB	10 Hz .. 5 kHz	10 Hz .. 20 kHz	10 Hz .. 20 kHz	10 Hz .. 20 kHz
Frequency limitation	Null	Null	See curve	See curve
Intrinsic uncertainty	≤ 1% + 4 mV	≤ 1% + 0.4 mV	≤ 1.5% + 40 mV (I < 10% I <sub>N</sub> ) ≤ 1% + 40 mV (I ≥ 10% I <sub>N</sub> )	≤ 1.5% + 4 mV (I < 10% I <sub>N</sub> ) ≤ 1% + 4 mV (I ≥ 10% I <sub>N</sub> )
Phase shift at 50 Hz	≤ 1° (0.5° typical)	≤ 1° (0.5° typical)	≤ 1° (0.5° typical)	≤ 1° (0.5° typical)

### Electrical specifications <sup>(1)</sup>

- **Operating voltage:**  
1,000 V<sub>RMS</sub> (Cat. IV)
- **Battery:**  
Two 1.5 V batteries (NEDA 15A, IEC LR6, AA)  
+5 V DC via a µUSB Type B connector
- **Battery life <sup>(2)</sup>:**  
300 hours typical  
1,800 10-minute approx. measurements
- **Consumption:**  
10 µA (OFF position)  
90 µA (sleep mode)
- **Battery level indication:**  
Flashing green LED (batteries voltage > 2 V)
- **Influence of battery voltage:**  
≤ 0.1 % (0.02 % typical) from 3.1 V to 2 V
- **Influence of temperature:**  
≤ 0.5 % (0.15 % typical) of output signal per 10 °K
- **Influence of relative humidity:**  
≤ 0.5 % (0.2 % typical) of output signal
- **Influence of conductor position in the sensor <sup>(3)</sup>:**  
≤ 2.5 % (1 % typical)
- **Influence of sensor deformation <sup>(4)</sup>:**  
≤ 1 % (0.2 % typical)
- **Influence of adjacent conductor <sup>(5)</sup>:**  
≤ I<sub>ADJ</sub> x 1 % (2 % near click-lock system)  
(0.2 % typical)
- **Input impedance of the measuring instrument:**  
≥ 1 MΩ
- **Common mode rejection <sup>(6)</sup>:**  
≤ 80 dB (100 dB typical)
- **Influence of the measurement instrument's impedance Z:**  
≤ 0.1 % at 10 kΩ

# FLEXIBLE PROBES FOR AC CURRENT

## Model A110 30-300-3,000-30,000/3

### Mechanical specifications

- **Clamping capacity:**  
Model length 120 cm: Ø max 36 cm
- **Bending radius:**  
≥ 40 mm
- **Operating temperature:**  
-10°C to +55°C
- **Storage temperature:**  
-40°C to +70°C
- **Max. temperature of clamped conductor (measured):**  
90 °C for 10 minutes max.
- **Relative humidity for operation:**  
0 to 85 % RH with a linear decrease above 35 °C
- **Operating altitude:**  
0 to 2,000 m
- **Casing protection rating (leakproofing):**  
Intermediate casing: IP54  
Flexible sensor: IP 67  
According to IEC 60529 Ed. 2.2-2013

- **Drop test:**  
1 m
- **Self-extinguishing capability:**  
Casing: UL94-V0  
Sensor: UL94 V0
- **Dimensions:**  
Intermediate casing: 120 x 55 x 39 (overall)  
Length of intermediate cable linking the sensor/processing unit: 2 m  
Length of output cable: 0.5 m  
Ø of sensor: 12 mm  
Connection cable Ø: 4 mm
- **Weight:**  
Model length 45 mm: 450 g  
Sensor: 30 g / 10 cm
- **Colours:**  
Sensor: red  
Sensor closing system: dark grey  
Intermediate casing: Dark grey
- **Output:**  
Two-wire cable with reinforced or double insulation terminated by 2 red and black isolated male banana plugs Ø 4 mm

### Safety specifications

- **Electrical safety:**  
Class II equipment with double or reinforced insulation between the primary and the secondary (winding connected to the connection cable) as per EN 61010-1 and 61010-2-032 Ed. 03-2012:  
- Sensor:  
Type B  
1,000 V Cat. IV pollution degree 2  
Intermediate casing:  
600 V Cat. III between the terminals and the external enclosure of the casing
- **Electromagnetic compatibility (EMC):** :  
Complies with the industrial environments according to EN 61326-1 Ed. 02-2012:  
Immunity to radiated fields: at 3 V/m, error ≤ 5% of measuring range (criterion A)

(1) Conditions of reference: 23 °C ± 5 °K, 20 % to 75 % RH

Battery voltage 3.2 V ± 0.1 VDC

Frequency and form of signal measured: 30 to 440 Hz sinusoidal

Continuous magnetic field < 40 A/m

Absence of external AC magnetic field

Absence of external electrical field

Measured conductor centred in the circular sensor (coil) after operation for 1 minute

Measurement instrument input impedance ≥ 1 MΩ

(2) With 3,000 mA/h batteries, for a supplied voltage between 3.2 V and 1.8 V (1.6 V to 0.9 V per battery), giving an average voltage of 2.8 V

(3) Whatever the conductor's position within the loop, as long as the sensor is not distorted (circular sensor)

(4) Oblong shape

(5) Adjacent conductor carrying an AC current  $I_{adj}$ , in contact with the sensor

(6) For a 600 V voltage applied between the enclosure and the secondary

### 3,000 A calibre

Frequency limitation according to amplitude

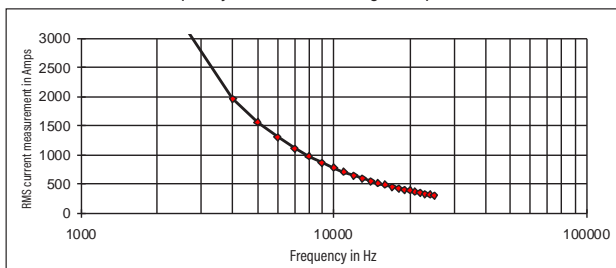

### 30,000 A calibre

Frequency limitation according to amplitude

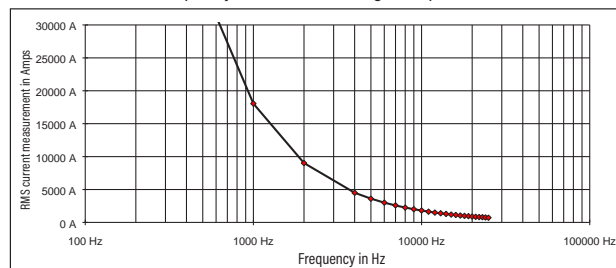

### To order

AmpFlex® A110 30-300-3k-30k A / 3 V, sensor length 120 cm,  
Output via cable terminated by 2 x Ø 4 mm isolated male banana plugs

### Reference

P01120632

# FLEXIBLE PROBES FOR AC CURRENT

## Model A110 30-300-3,000-30,000/3

### Frequency response

#### 30 A calibre

Typical error on measurement according to frequency for a current of 2 A

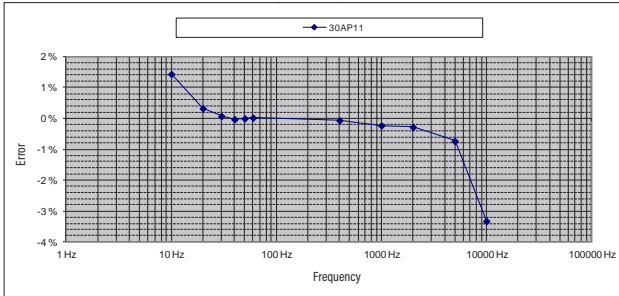

Typical phase shift according to frequency for a current of 2 A

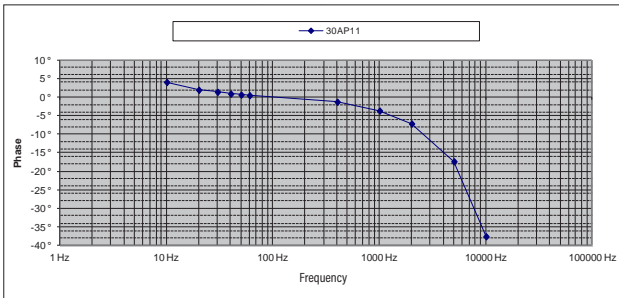

#### 300 A calibre

Typical error on measurement according to frequency for a current of 20 A

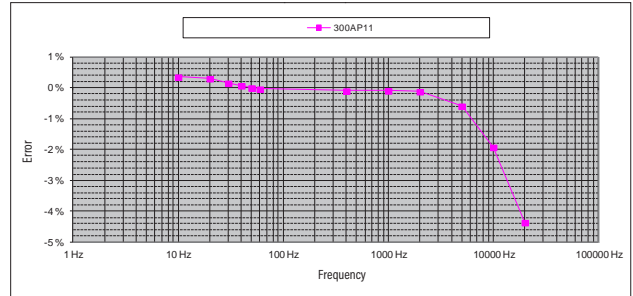

Typical phase shift according to frequency for a current of 20 A

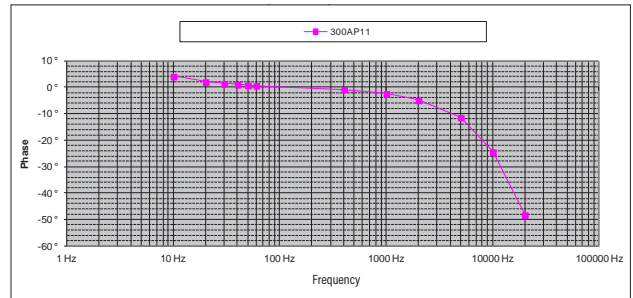

#### 3,000 A calibre

Typical error on measurement according to frequency for a current of 20 A

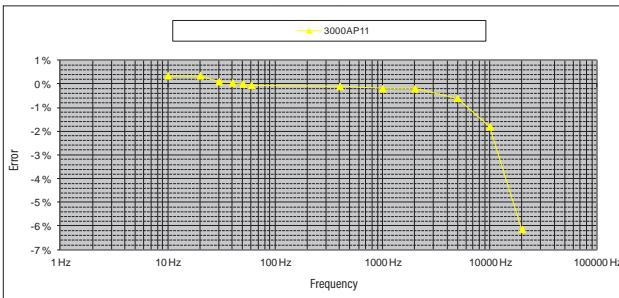

Typical phase shift according to frequency for a current of 20 A

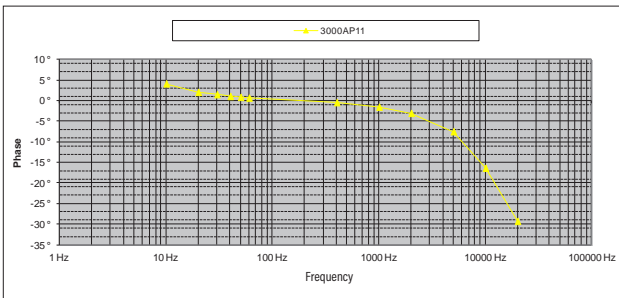

#### 30,000 A calibre

Typical error on measurement according to frequency for a current of 20 A

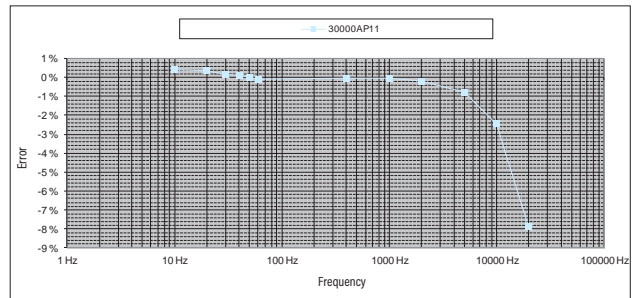

Typical phase shift according to frequency for a current of 20 A

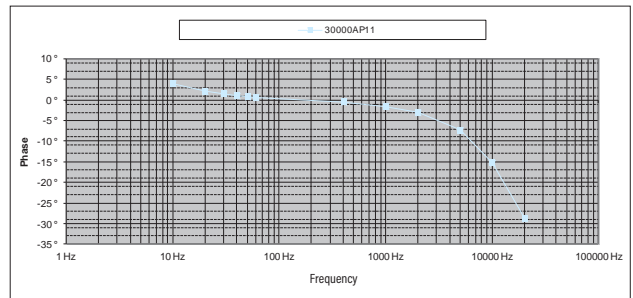

# FLEXIBLE PROBES FOR AC CURRENT

## Model A110 30-300-3,000-30,000/3

### Configurations

#### Level 1

A 1 1 0

**1 Family of products**

**2 Lead length in centimeters**

Min value : 050 (50 cm)  
 Max value : 995 (9.95 m)  
 Increment per 5 cm section

**3 Length of connection lead in centimeters**

Min value : 050 (50 cm)  
 Max value : 995 (9.95 m)  
 Increment per 5 cm section

**4 Output via**

A: coaxial cable of the length to be defined in 5 terminated by a 600 V CAT III isolated male BNC socket  
 B: cable 50 cm long terminated by 2 red/black Ø 4 mm isolated male banana plugs rated 600 V CAT IV  
 C: shielded cable with 2 bared, tin-plated conductors of the length to be defined in 5, rated 600 V CAT IV

**5 Output cable length in cm**

If 4 = "A"  
 Min value : 050 (50 cm)  
 Max value : 110 (1.10 m)  
 Increment per 5 cm section

If 4 = "C"  
 Min value : 050 (50 cm)  
 Max value : 995 (9.95 m)  
 Increment per 5 cm section

**6 Measurement calibres (sensitivities)**

A: 3 A-30 A-300 A -3,000 A/3 V (1 V-100 mV-10 mV-1 mV/A)  
 B: 30 A - 300 A - 3,000 A - 30,000 A / 3 V (100 mV - 10 mV - 1 mV - 0.1 mV / A)

A 1 1 0

.. .. ..

On request - Modulo 5 cm  
 Coding over 3 characters  
 E.g. 50 cm = 050; 9 m = 900

.. .. ..

On request - Modulo 5 cm  
 Coding over 3 characters  
 E.g. 50 cm = 050; 9 m = 900

..

.. .. ..

On request - Modulo 5 cm  
 Coding over 3 characters  
 E.g. 50 cm = 050; 1 m = 100

..

Reference: (products available in stock)	Coded codes
A 1 1 0 0 8 0 2 0 0 B 0 5 0 A	P01120631
A 1 1 0 1 2 0 2 0 0 B 0 5 0 B	P01120632

# FLEXIBLE PROBES FOR AC CURRENT

## Model A130 30-300-3,000/3 Three-phase

Current	30 A AC	300 A AC	3,000 AAC
Output	100 mV/A	10 mV/A	1 mV/A

### Description

The AmpFlex® A130 is a flexible sensor which comprises an active part (Rogowski coil) and a casing containing an electronic processing unit.

Unlike current clamps using magnetic circuits, the AmpFlex® models are flexible sensors without magnetic saturation constraints. As a result, they offer excellent linearity, low phase shift, a large dynamic range for measurement (up to several kA) while remaining easy to use.

The sensors' flexibility makes it simple to clamp and measure any conductor, whatever its type (cable, busbar, strand, etc. and accessibility).

The design of the click-together opening and closing system means it can be handled with protective gloves.

The AmpFlex® A130 can be connected to the AC voltage input (mV AC, V AC) of any multimeter or measuring instrument equipped with Ø 4 mm female banana plugs.

The AmpFlex® A130 can be powered by batteries or a standard external power supply. If the power supply fails, the instrument's batteries take over.

To maximize the battery life, the MiniFlex A130 has an automatic standby system which can be deactivated at start-up to perform long-term measurement campaigns. The MiniFlex A130 has 3 green, yellow and red LEDs indicating, respectively, the power supply status, the status of the automatic standby function and any overruns of the measurement capacity.



### Specifications for current measurement <sup>(1)</sup>

Calibre (I <sub>N</sub> )	30 A	300 A	3,000 A
Measurement range in use	0.5 .. 30 A AC	0.5 .. 300 A AC	0.5 .. 3,000 A AC
Specified measurement range	5 .. 30 A AC	5 .. 300 A AC	50 .. 3,000 A AC
Output/input ratio	100 mV / A	10 mV / A	1 mV / A
Bandwidth at -3 dB	10 Hz .. 20 kHz	10 Hz .. 20 kHz	10 Hz .. 20 kHz
Frequency limitation	Null	Null	See curve
Intrinsic uncertainty	≤ 1 % + 4 mV	≤ 1.5 % + 0.4 mV (I < 10 % I <sub>N</sub> ) ≤ 1 % + 0.4 mV (I ≥ 10 % I <sub>N</sub> )	≤ 1.5 % + 0.04 mV (I < 10 % I <sub>N</sub> ) ≤ 1 % + 0.04 mV (I ≥ 10 % I <sub>N</sub> )
Phase shift at 50 Hz	≤ 1° (0.5° typical)	≤ 1° (0.5° typical)	≤ 1° (0.5° typical)

### Electrical specifications <sup>(1)</sup>

- **Operating voltage:**  
1,000 V<sub>RMS</sub> (Cat. IV)
- **Battery:**  
Two 1.5 V batteries (NEDA 15A, IEC LR6, AA)  
+5 V DC via a µUSB Type B connector
- **Battery life <sup>(2)</sup>:**  
500 hours typical  
3,000 10-minute approx. measurements
- **Consumption:**  
10 µA (OFF position)  
90 µA (sleep mode)
- **Battery level indication:**  
Flashing green LED (batteries voltage > 2 V)
- **Influence of battery voltage:**  
≤ 0.1 % (0.02 % typical) from 3.1 V to 2 V
- **Influence of temperature:**  
≤ 0.5 % (0.15 % typical) of output signal per 10 °K
- **Influence of relative humidity:**  
≤ 0.5 % (0.2 % typical) of output signal
- **Influence of conductor position in the sensor <sup>(3)</sup>:**  
≤ 2.5 % (1 % typical)
- **Influence of sensor deformation <sup>(4)</sup>:**  
≤ 1 % (0.2 % typical)
- **Influence of adjacent conductor <sup>(5)</sup>:**  
≤ I<sub>ADJ</sub> x 1 % (2 % near click-lock system)  
(0.2 % typical)
- **Input impedance of the measuring instrument:**  
≥ 1 MΩ
- **Common mode rejection <sup>(6)</sup>:**  
≤ 80 dB (100 dB typical)
- **Influence of the measurement instrument's impedance Z:**  
≤ 0.1 % at 10 kΩ

# FLEXIBLE PROBES FOR AC CURRENT

## Model A130 30-300-3,000/3 Three-phase

### Mechanical specifications

- Clamping capacity:**  
Model length 80 cm: Ø max 23.5 cm
- Bending radius:**  
≥ 40 mm
- Operating temperature:**  
-10°C to +55°C
- Storage temperature:**  
-40°C to +70°C
- Max. temperature of clamped conductor (measured):**  
90 °C for 10 minutes max.
- Relative humidity for operation:**  
0 to 85 % RH with a linear decrease above 35 °C
- Operating altitude:**  
0 to 2,000 m
- Casing protection rating (leakproofing):**  
Intermediate casing: IP54  
Flexible sensor: IP 67  
According to IEC 60529 Ed. 2.2-2013

- Drop test:**  
1 m (CEI 68-2-32)
- Self-extinguishing capability:**  
Casing: UL94-V0  
Sensor: UL94 V0
- Dimensions:**  
Intermediate casing: 120 x 55 x 39 (overall)  
Length of intermediate cable linking the sensor/ processing unit: 3 m  
Length of output cable: 0.5 m  
Ø of sensor: 12 mm  
Connection cable Ø: 4 mm
- Weight:**  
1 kg
- Colours:**  
Sensor: red  
Sensor closing system: dark grey  
Intermediate casing: Dark grey
- Output:**  
3 coaxial cables with reinforced or double isolation terminated by 1 black isolated male BNC plug

### Safety specifications

- Electrical safety:**  
Class II equipment with double or reinforced insulation between the primary and the secondary (winding connected to the connection cable) as per EN 61010-1 and 61010-2-032 Ed. 03-2012:
  - Sensor:
    - Type B
    - 1,000 V Cat. IV pollution degree 2
  - Intermediate casing:
    - 600 V Cat. III between the BNC output and the external enclosure of the casing
- Electromagnetic compatibility (EMC):** :  
Complies with the industrial environments according to EN 61326-1 Ed. 02-2012:
  - Immunity to radiated fields: at 3 V/m, error ≤ 5% of measuring range (criterion A)

- Conditions of reference: 23 °C ± 5 °K, 20 % to 75 % RH  
Battery voltage 3.2 V ± 0.1 VDC  
Frequency and form of signal measured: 30 to 440 Hz sinusoidal  
Continuous magnetic field < 40 A/m  
Absence of external AC magnetic field  
Absence of external electrical field  
Measured conductor centred in the circular sensor (coil) after operation for 1 minute  
Measurement instrument input impedance ≥ 1 MΩ
- With 3,000 mA/h batteries, for a supplied voltage between 3.2 V and 1.8 V (1.6 V to 0.9 V per battery), giving an average voltage of 2.8 V
- Whatever the conductor's position within the loop, as long as the sensor is not distorted (circular sensor)
- Oblong shape
- Adjacent conductor carrying an AC current  $I_{adj}$ , in contact with the sensor
- For a 600 V voltage applied between the enclosure and the secondary
- Delivered with a set of 3 female BNC/ Ø 4 mm isolated male banana adapters with 19 mm spacing and a set of identifiers (12 colours)

### 3,000 A calibre

Frequency limitation according to amplitude

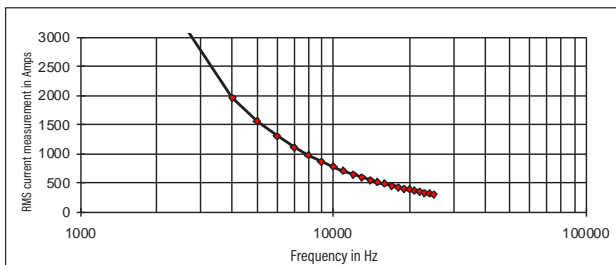

To order	Reference
AmpFlex® A130 30-300-3,000 A / 3 V, sensor length 80 cm, output via 3 coaxial cables terminated by 1 isolated security BNC lead <sup>(7)</sup>	P01120633

# FLEXIBLE PROBES FOR AC CURRENT

## Model A130 30-300-3,000/3 Three-phase

### Frequency response

#### 30 A calibre

Typical error on measurement according to frequency for a current of 20 A

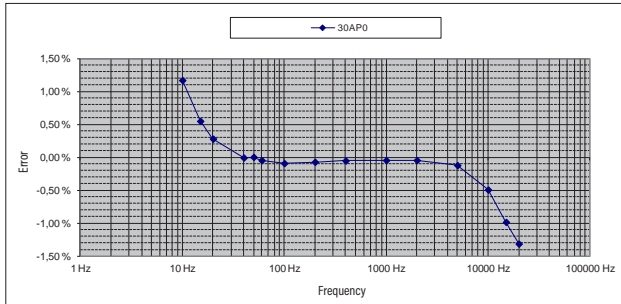

#### 300 A calibre

Typical error on measurement according to frequency for a current of 20 A

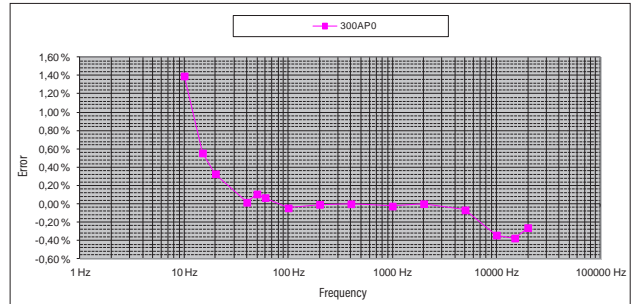

Typical phase shift according to frequency for a current of 20 A

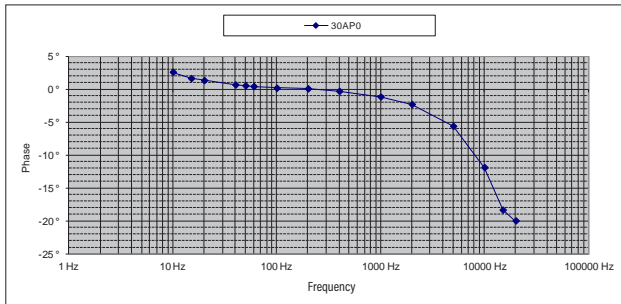

Typical phase shift according to frequency for a current of 20 A

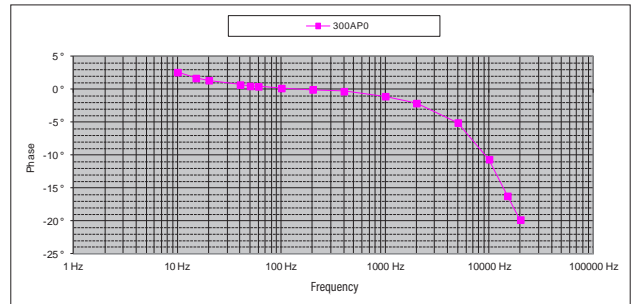

#### 3,000 A calibre

Typical error on measurement according to frequency for a current of 20 A

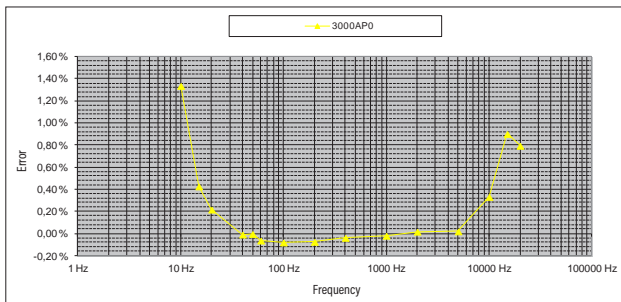

Typical phase shift according to frequency for a current of 20 A

